

Loarennoù

Mise en réseau des satellites

Équipe étudiante
Jules MALLET, Jérisa SINJAKU,
Estelle BROSSARD, Coline CAILLAUD

Équipe enseignante
Nadia SBITI
Stéphane CHEVRIER
Nadia PERROTEAU



Rappel des enjeux

- Renforcer l'attractivité économique des Forges, fondement de la mémoire ouvrière
- Dynamiser le territoire
- Équilibrer le territoire

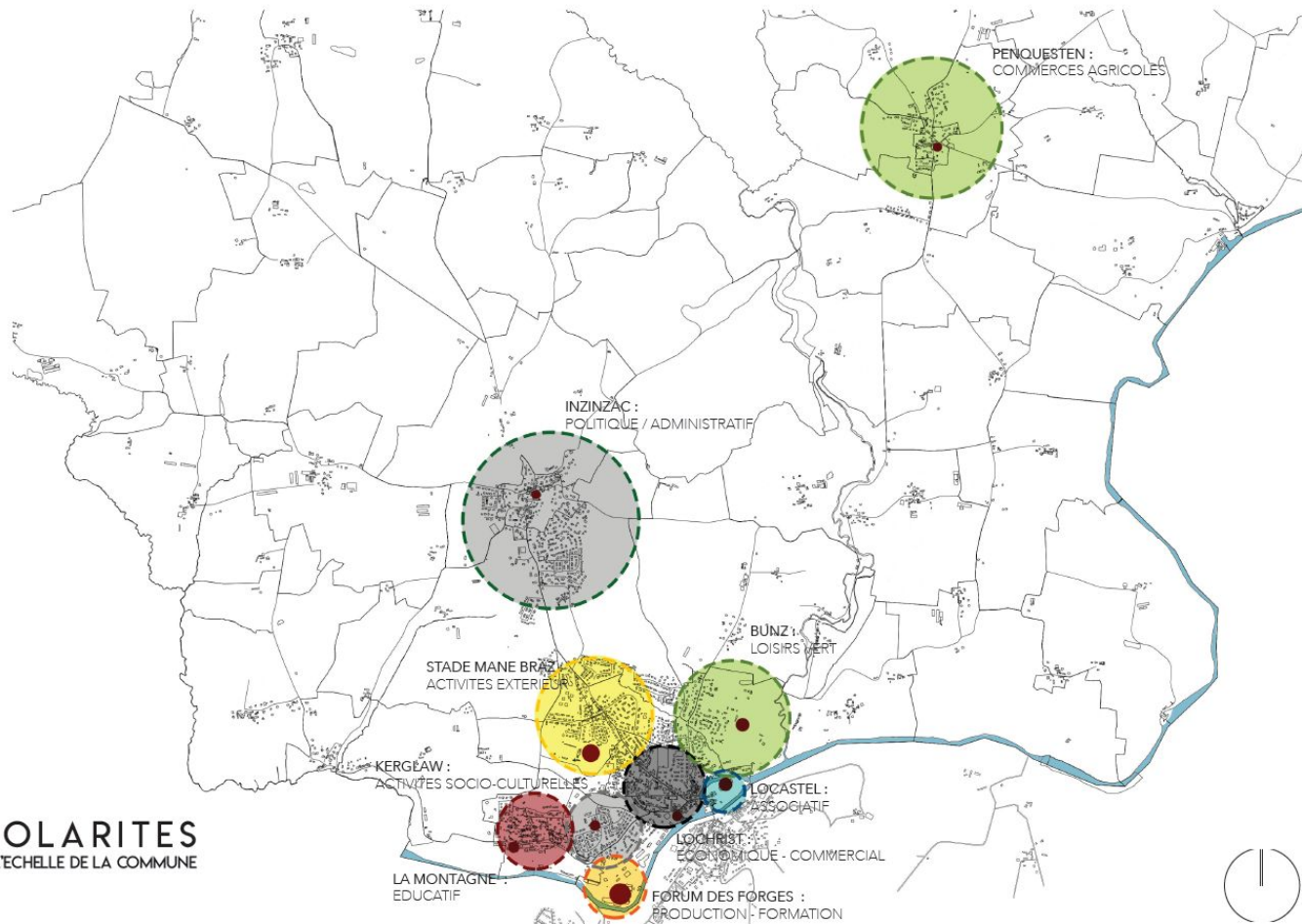

POLARITES
A L'ECHELLE DE LA COMMUNE



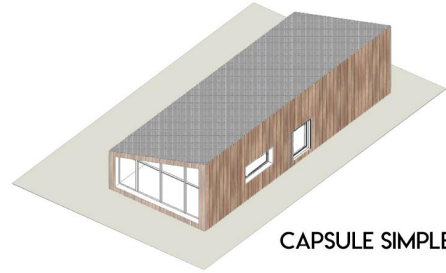

CAPSULE SIMPLE



ÉVOLUTION DU QUARTIER
À L'HORIZON
2025

- ACQUISITION DE LA FERME
- /// TRAVAIL SUR LA VOIRIE
- MISE EN PLACE DE L'AXE AÉRIEN
- VALORISATION DES ESPACES VERTS
- PAR L'ORGANISATION DE RASSEMBLEMENTS
- ⊠ ACQUISITION FONCIÈRE SUR L'AXE DU MAIL



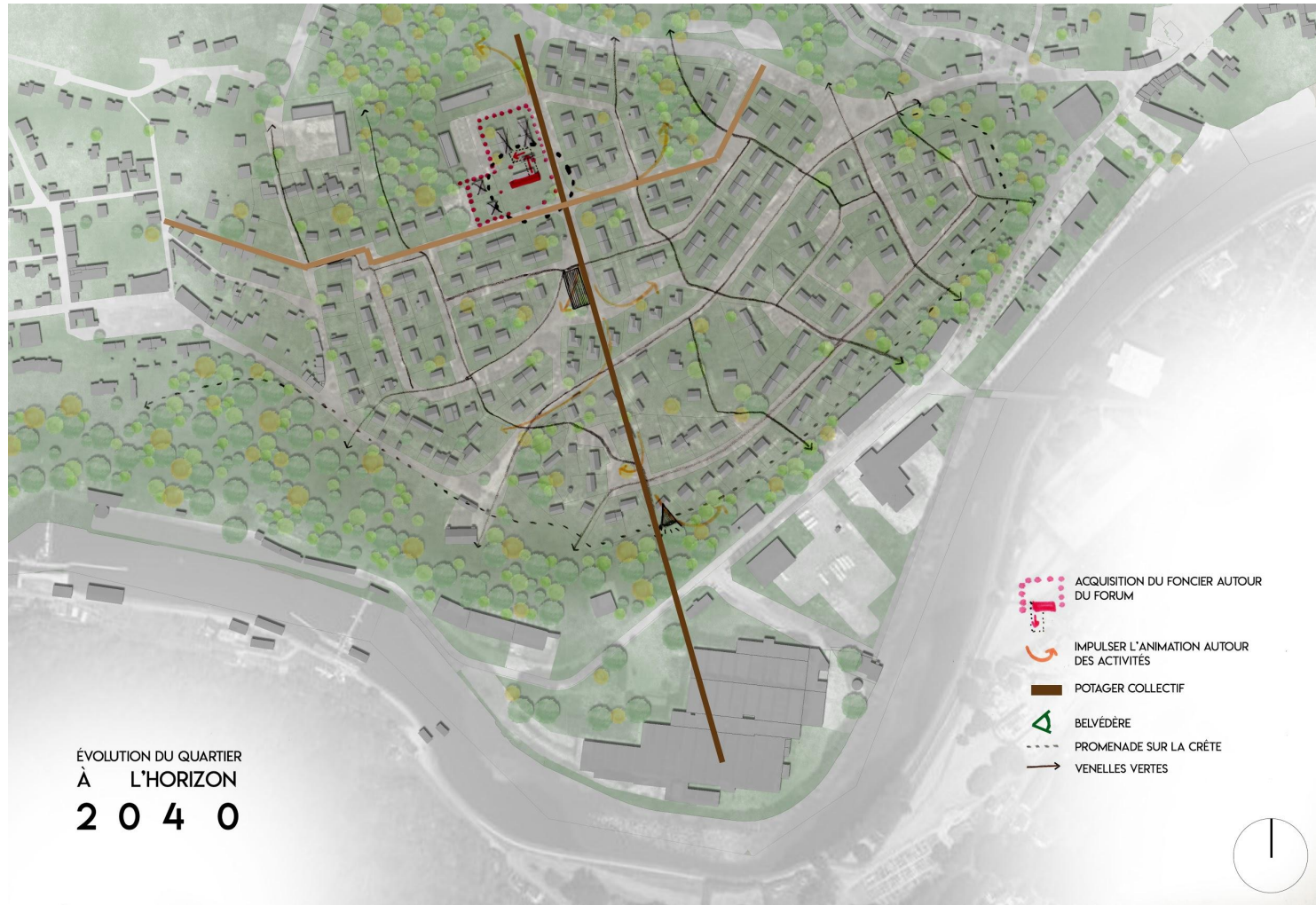

ÉVOLUTION DU QUARTIER
À L'HORIZON
2040

-  ACQUISITION DU FONCIER AUTOUR DU FORUM
-  IMPULSER L'ANIMATION AUTOUR DES ACTIVITÉS
-  POTAGER COLLECTIF
-  BELVÈDÈRE
-  PROMENADE SUR LA CRÈTE
-  VENELLES VERTES





ÉVOLUTION DU QUARTIER
À L'HORIZON
2060

-  DÉVELOPPEMENT DU FORUM
-  CAPSULES D'ÉQUIPEMENTS
-  PLACETTES DÉDIÉES AUX RASSEMBLEMENTS
-  AXES AUTOPARTAGE
-  ZONES DISPONIBLES POUR IMPLANTER LES CAPSULES D'HABITATION
-  CAPSULES TOURISTIQUES



FORUM PERIURBAIN

AU COEUR DE LA VILLE SATELLITE

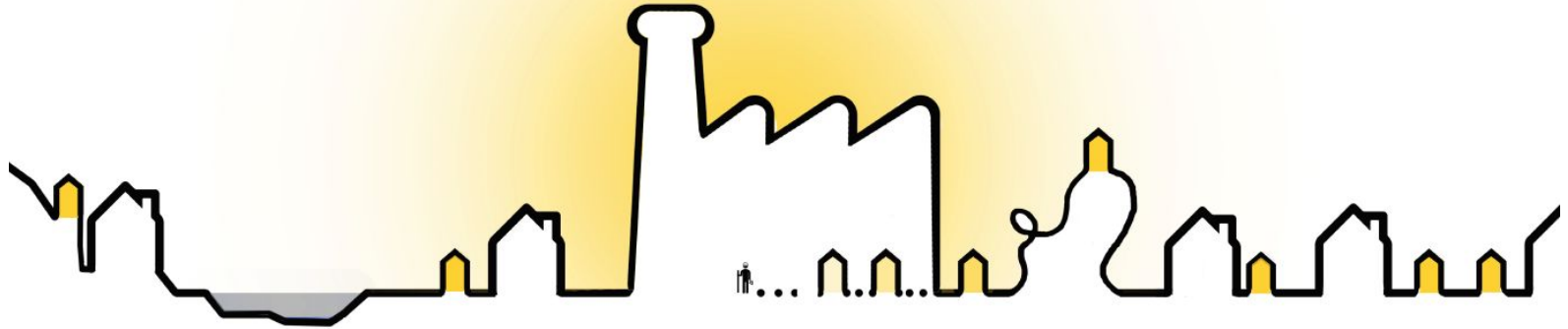

- FORUM -

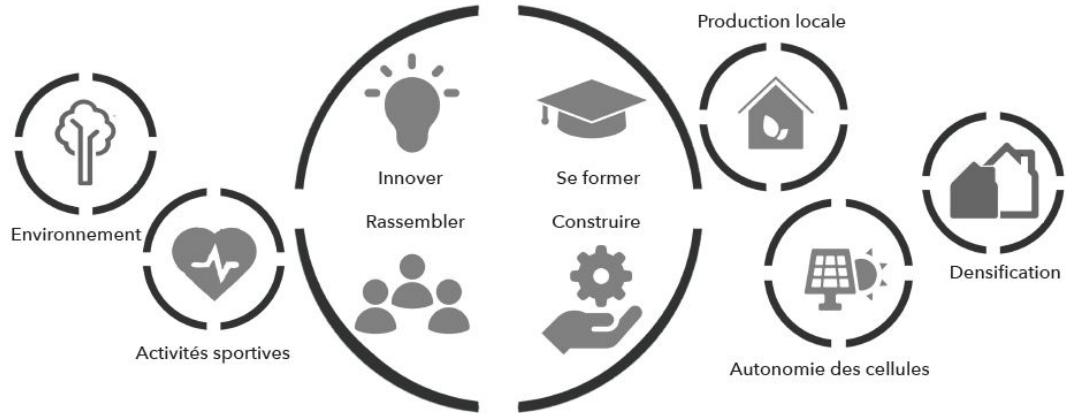



REFERENCES MAISONS TRANSPORTABLES

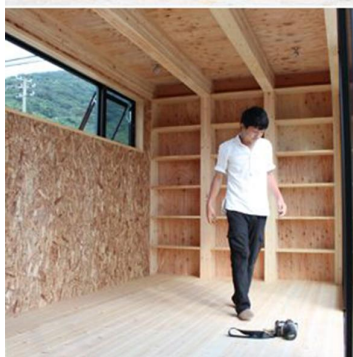

Maison Transportable



Maison Minimod - MAPA



Maison Cabane - Whangapoua



Mima LIGHT



Pobble House - Guy Hollaway Architectes

LA CAPSULE – LE MODE D'HABITAT FUTUR

PRINCIPES CONCEPTUELS



COMPACTITÉ

- PARALLÉLÉPIPÈDE RECTANGLE DE 4M X 10M X 4.4M
- FACILITÉ DE TRANSPORT

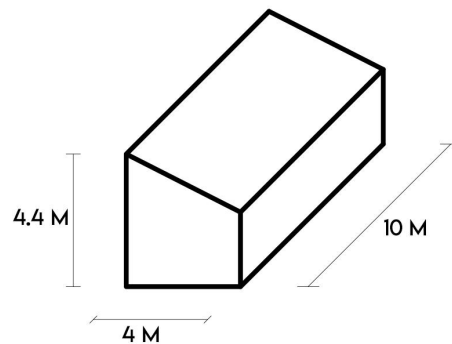

FLEXIBILITÉ

- LIBERTÉ D'ORGANISATION DU PLAN
- POSSIBILITÉ DE CRÉER DES TERRASSES PRIVÉES

UN MODULE – PLUSIEURS TYPOLOGIES

- POSSIBILITÉS DE COMBINER LE MODULE AFIN DE CRÉER DES BÂTIMENTS D'HABITATION ET D'ÉQUIPEMENT

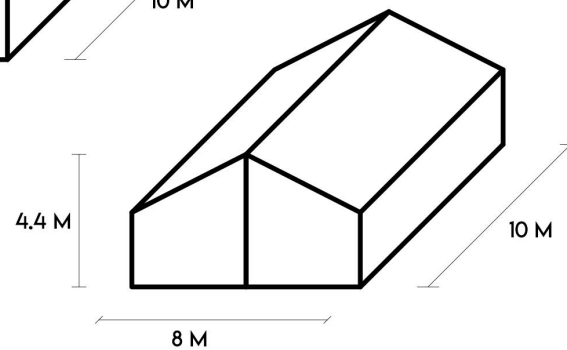
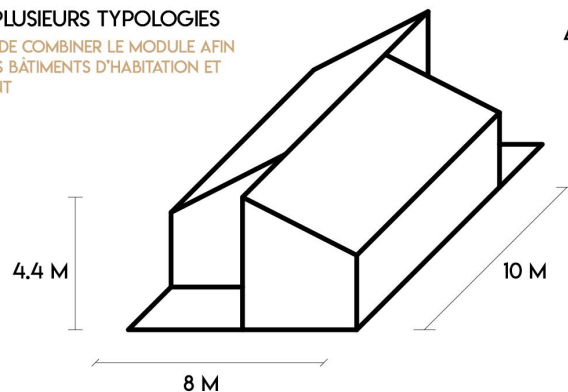

LA CAPSULE – LE MODE D'HABITAT FUTUR

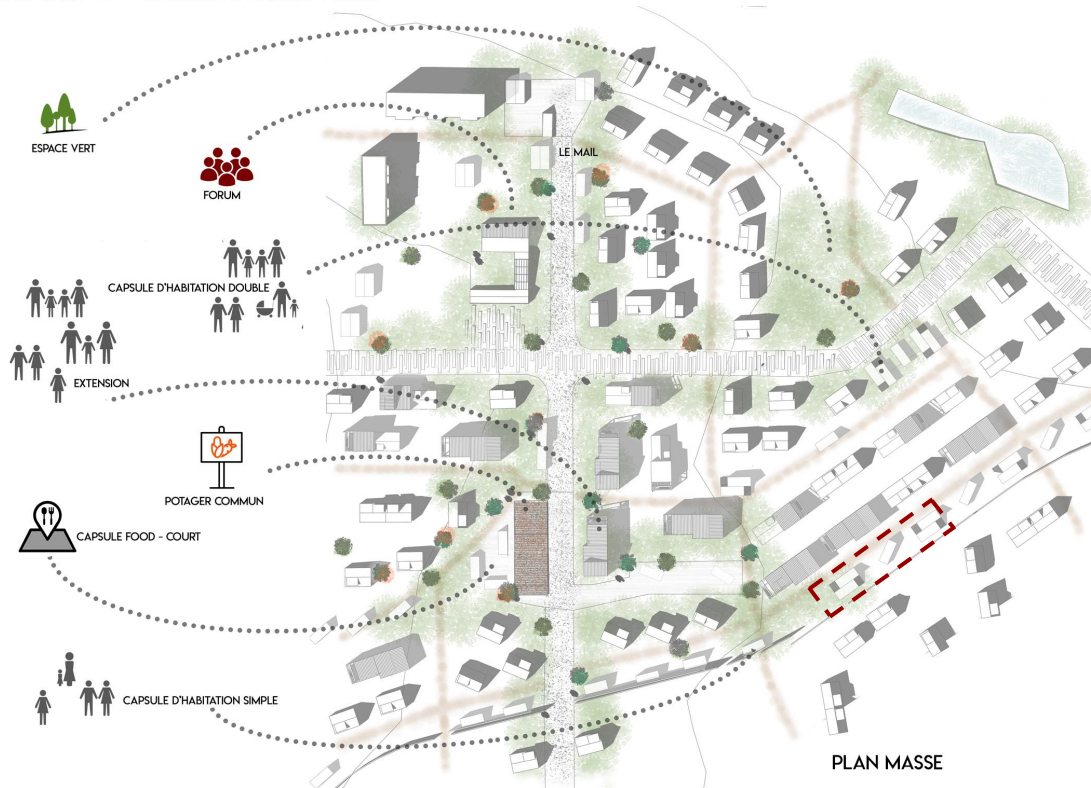

PLAN MASSE

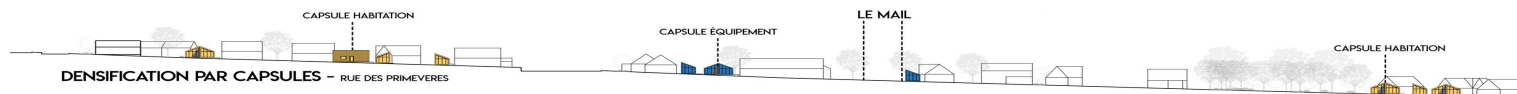

DENSIFICATION PAR CAPSULES - RUE DES PRIMEVERES

LA CAPSULE – LE MODE D'HABITAT FUTUR

UN HABITAT - PLUSIEURS PROFILS SOCIOLOGIQUES



CAPSULE SIMPLE

35 M² HABITABLES

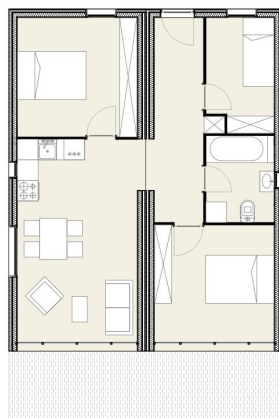

CAPSULE DOUBLE

70 M² HABITABLES



CAPSULE DOUBLE

70 M² HABITABLES

LA CAPSULE – LE MODE D'HABITAT FUTUR

CAPSULES D'ÉQUIPEMENTS

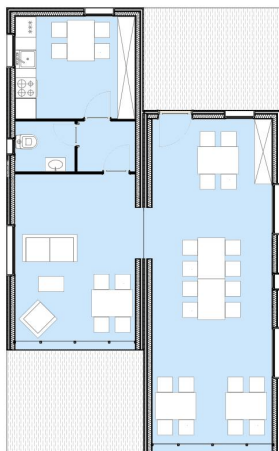

CAPSULES DE CO-WORKING

70 M²

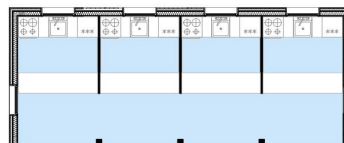
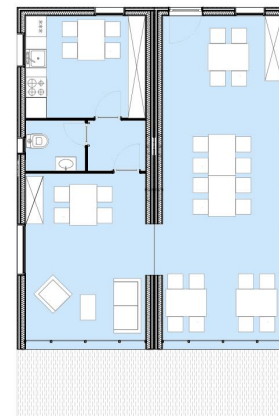

CAPSULES DE FOOD - COURT

35 M²

LA CAPSULE – LE MODE D'HABITAT FUTUR

ASPECT DES CAPSULES - PRINCIPES DES VUES

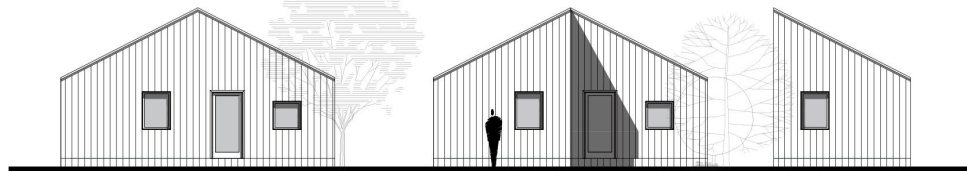

FAÇADES EST

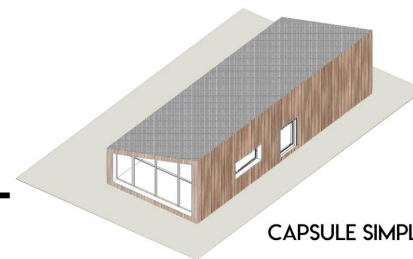

CAPSULE SIMPLE

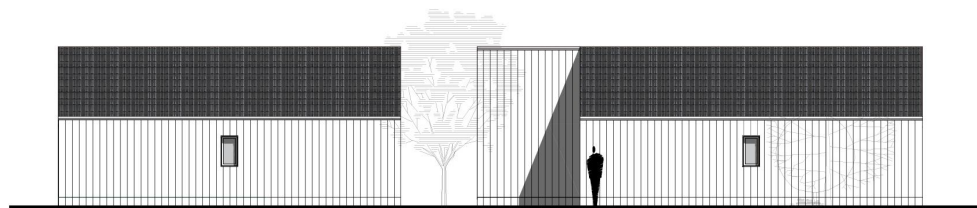

FAÇADES NORD

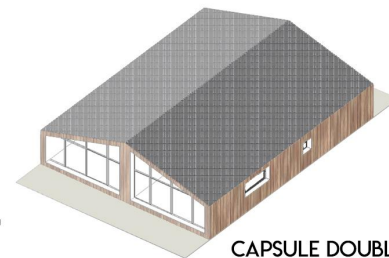

CAPSULE DOUBLE 1



FAÇADES SUD

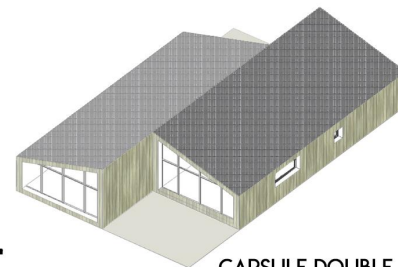

CAPSULE DOUBLE 2



LA CAPSULE – LE MODE D'HABITAT FUTUR

PRINCIPE CONSTRUCTIF

- MATÉRIAUX LOCAUX BIOSOURCÉS
- IMPACT MINIMAL AU SOL



COMPOSITION DU MUR EN OSSATURE BOIS

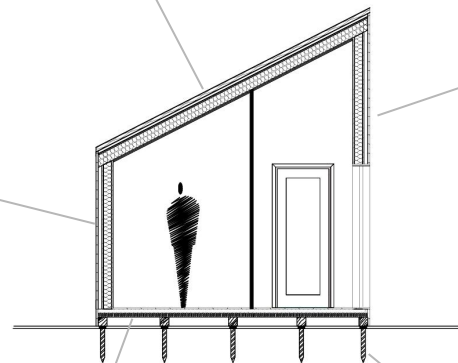
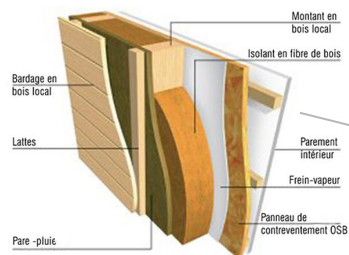

COUPE TRANSVERSALE

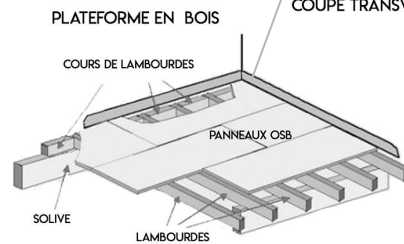

PLATEFORME EN BOIS

OSSATURE BOIS LOCAL



FONDATION À VIS





LA CAPSULE – LE MODE D'HABITAT FUTUR

VUE INTÉRIEURE



LA CAPSULE - EXTENSION - REHABILITATION
ALTERNATIVE AUX CAPSULES EX-NIHILO



LA CAPSULE - EXTENSION - REHABILITATION

TRAVAIL D'ANALYSE DES TYPOLOGIES



RDC+COMBLES



RDC+COMBLES+SOUS-SOL



RDC+COMBLES+GARAGE



RDC+COMBLES+AVANCEE



RDC+COMBLES+AVANCEE+SOUS-SOL



RDC+ETAGE+COMBLES+GARAGE



RDC+ETAGE+COMBLES+SS



CONTEMPORAIN

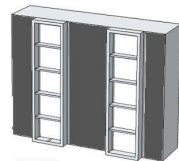

COLLECTIF



LA CAPSULE - EXTENSION - REHABILITATION

PHOTOGRAPHIE DES TYPOLOGIES SUR LEQUEL SE PORTE LE TRAVAIL



LA CAPSULE - EXTENSION - REHABILITATION

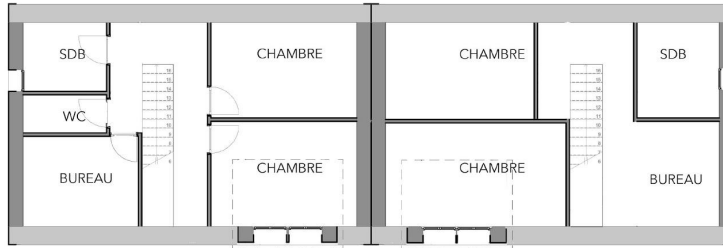

R+1

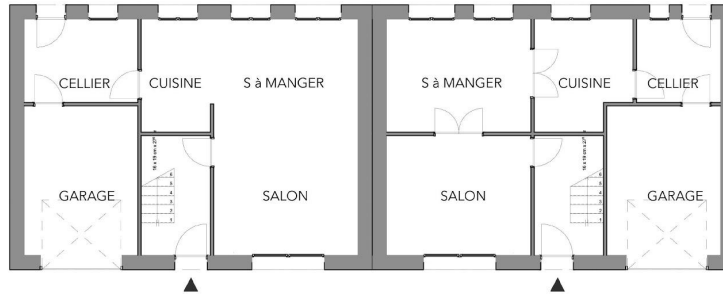

RDC

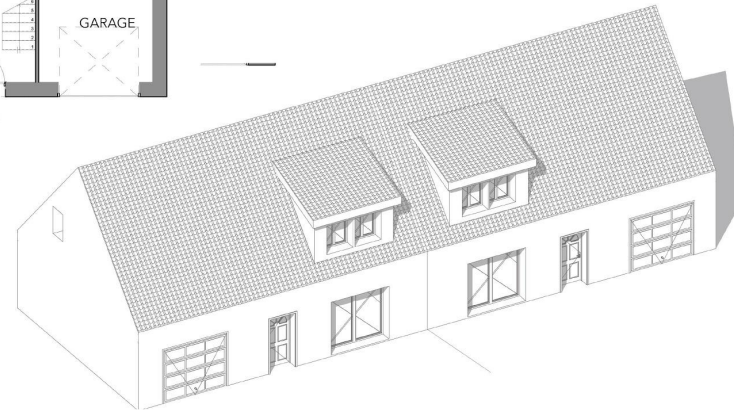

PLAN TYPE DES MAISONS MITOYENNES

LA CAPSULE - EXTENSION - REHABILITATION

PRINCIPES DE FONCTIONNEMENT DES EXTENSIONS

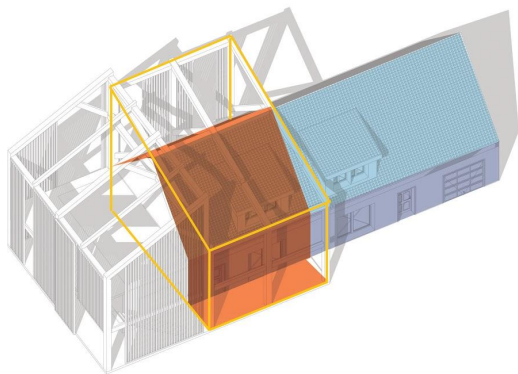

AMELIORER LES PERFORMANCES
DU BATI TRADITIONNEL

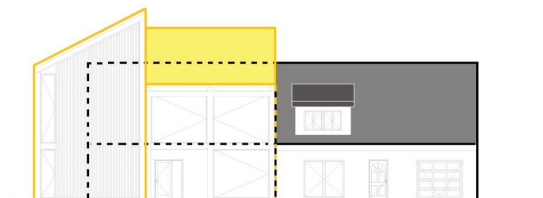

MODIFIER LA MORPHOLOGIE
DU QUARTIER

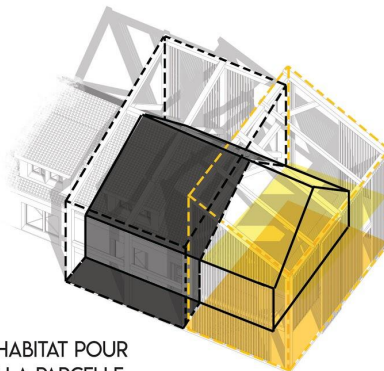

DIVISER L'HABITAT POUR
DENSIFIER LA PARCELLE

LA CAPSULE - EXTENSION - REHABILITATION

CHOIX DES MAISONS A VALORISER



ZOOM SUR PLAN MASSE



LA CAPSULE - EXTENSION - REHABILITATION

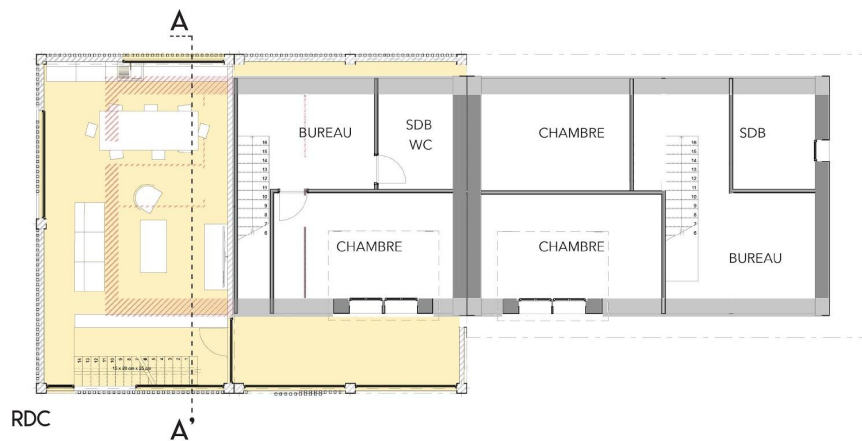
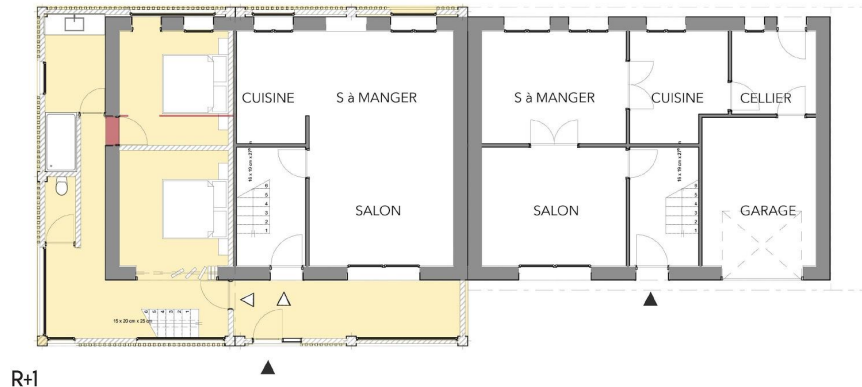

PLAN DE L'EXTENSION NUMERO 1

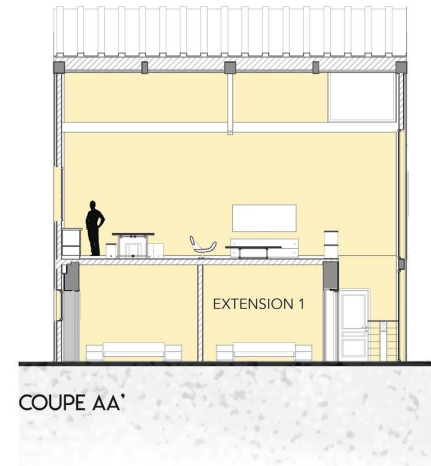

LA CAPSULE - EXTENSION - REHABILITATION
VUE INTERIEUR DEPUIS LA CUISINE AU R+1



LA CAPSULE - EXTENSION - REHABILITATION

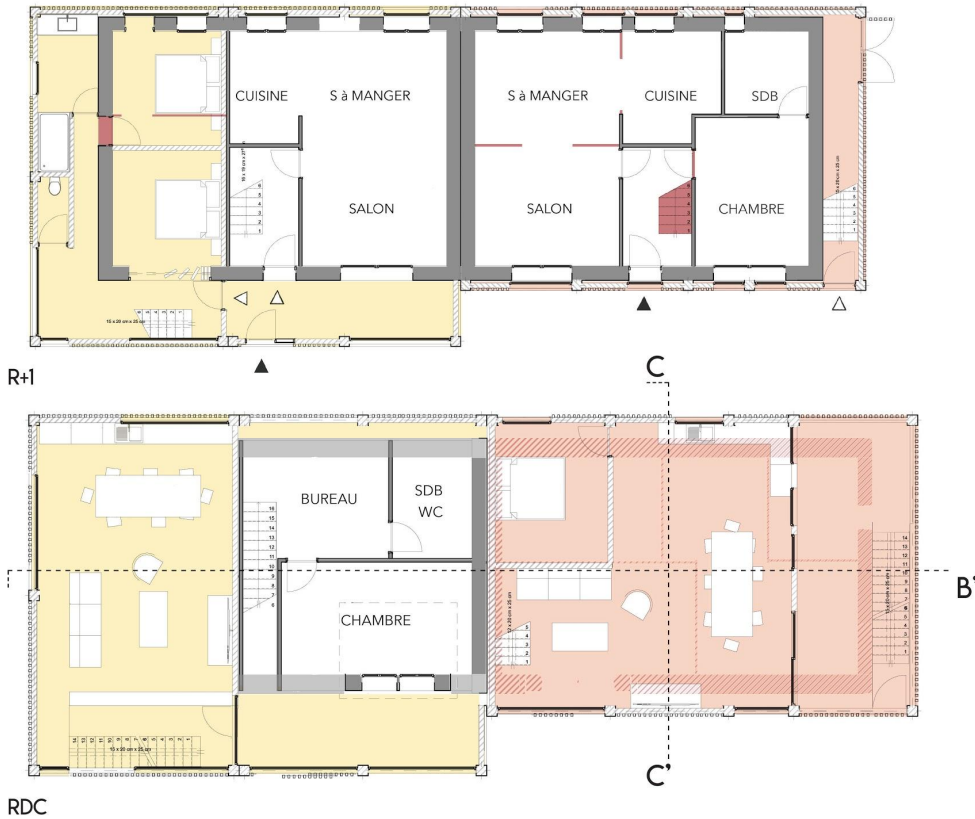

PLANS DE L'EXTENSION NUMERO 2

LA CAPSULE - EXTENSION - REHABILITATION

FONCTIONNEMENT DES 4 LOGEMENTS



LA CAPSULE - EXTENSION - REHABILITATION

AXONOMETRIE STRUCTURELLE

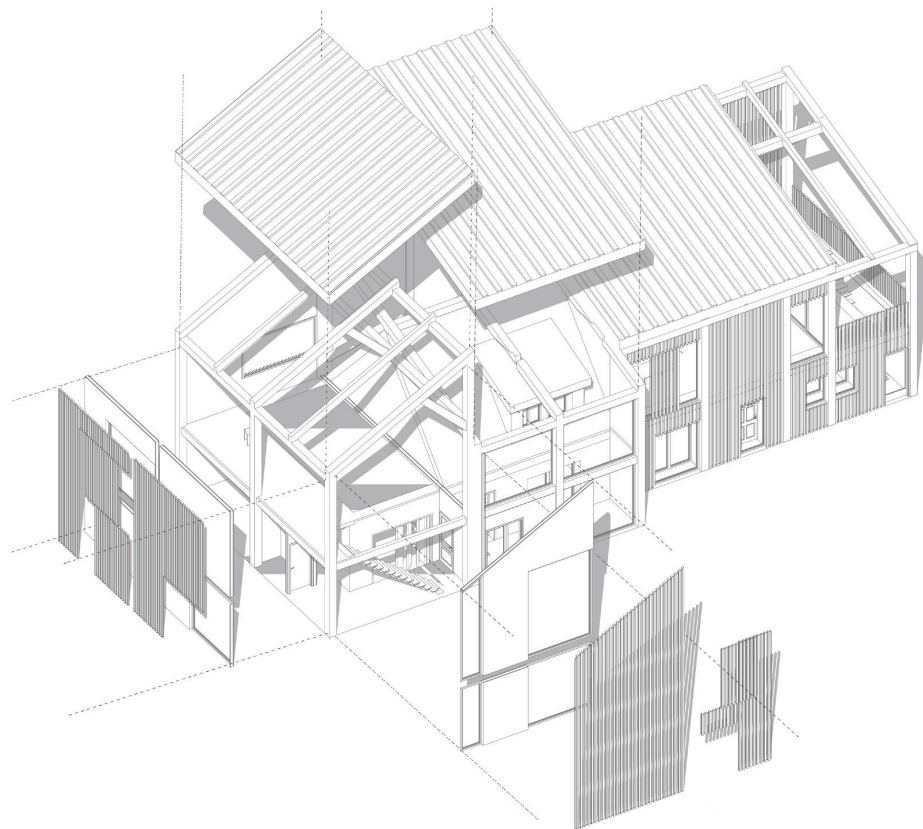

TOITURE CELLOZ



ARCHE SAPIN



BARDAGE CHENE

LA CAPSULE - EXTENSION - REHABILITATION

AXONOMETRIE DE L'ETAT PROJETE DU QUARTIER DE KERGLAW



EQUIPEMENTS

CAPACITE D'HEBERGEMENT DES CAPSULES

LA CAPSULE - EXTENSION - REHABILITATION
VISUALISATION DE LA VIE SUR LE MAIL

